



广东岭南职业技术学院
GUANGDONG LINGNAN
POLYTECHNIC

智能制造学院

模具设计与制造专业

浇注系统设计





01

定位环设计



(1) 添加定位环，并对A板求腔



更新警告和失败报告

(不用理会)

17MJ001_fhcs_075

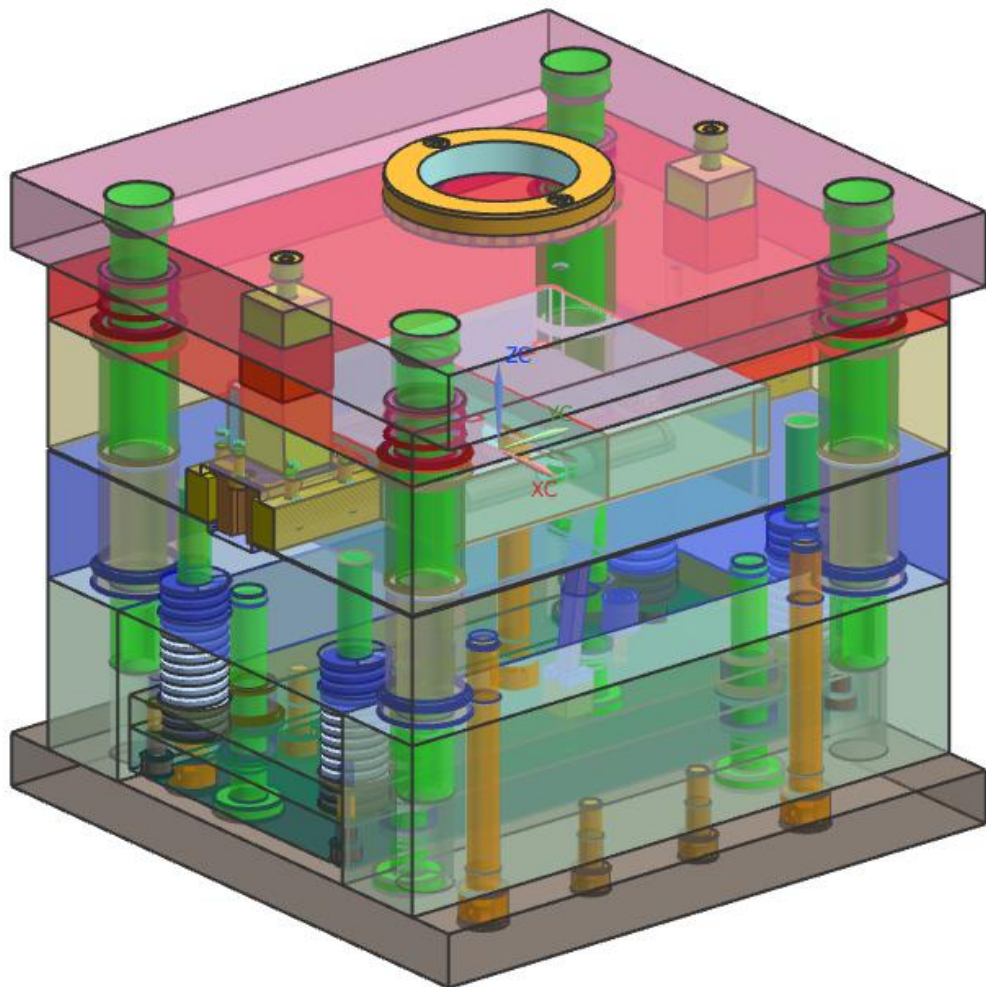



02

浇口套设计





- (1) 使成为**工作**部件：17MJ001_misc_side_a_014.prt
- (2) “新建组件”：17MJ001_sprue_bushing.prt
(注意选择文件夹：17MJ001)
- (3) 将17MJ001_sprue_bushing.prt 设置为显示部件
- (4) 在部件导航器中，将基准坐标系显示出来
- (5) 工作图层：251层
- (6) 在ZX基准面上创建草图

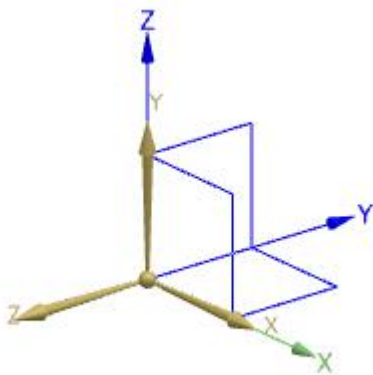

(7) 绘制草图曲线

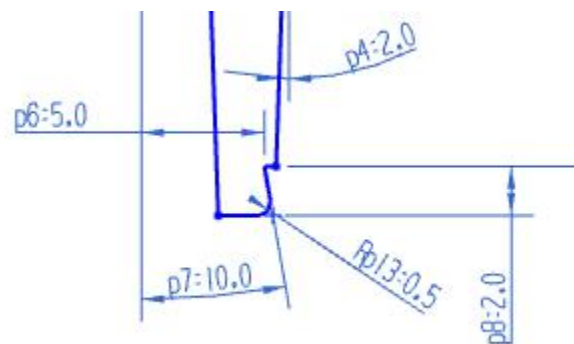
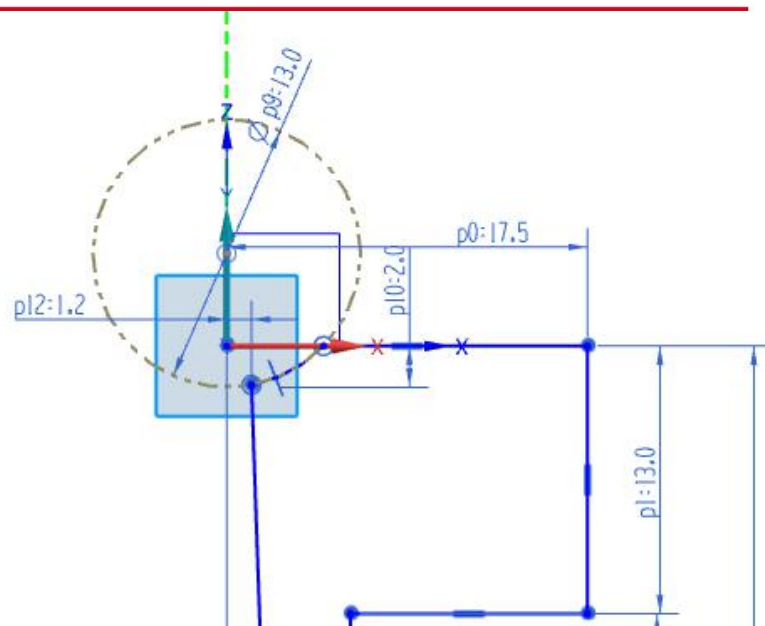
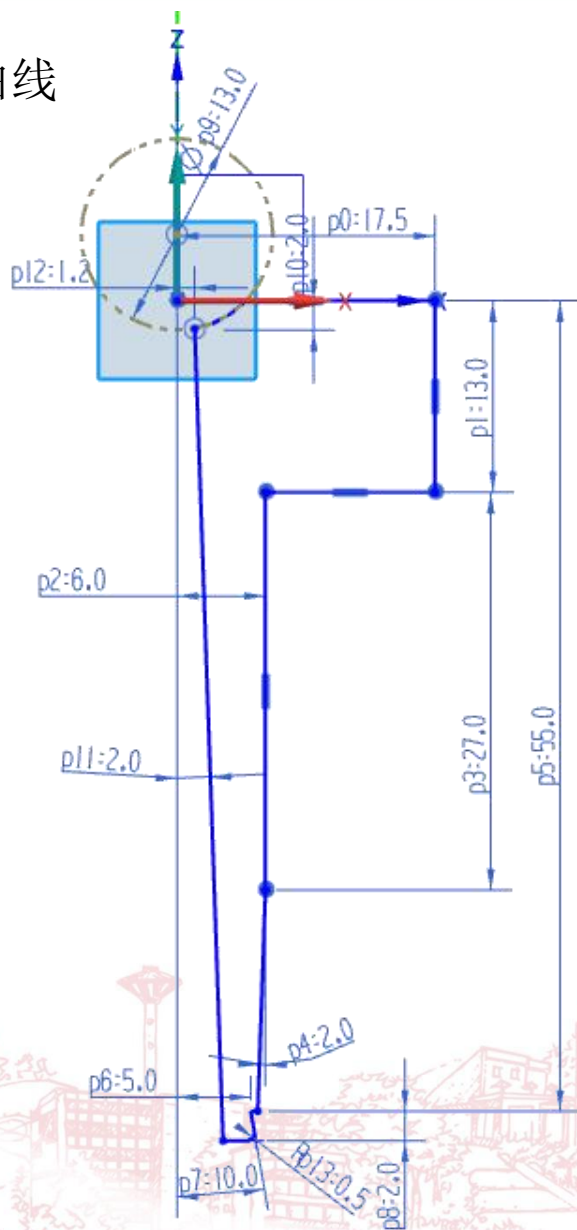



(8) 工作图层: 1

(9) 旋转草图, 得到实体

(10) 创建引用集: TRUE, 对象为回转体

(11) 工作图层: 99

(12) "抽取几何体"

(13) 删除抽取体中的球面与圆锥孔

(14) 创建引用集: FALSE, 对象为抽取体; 设置假体: 深蓝色、虚线、透明度80

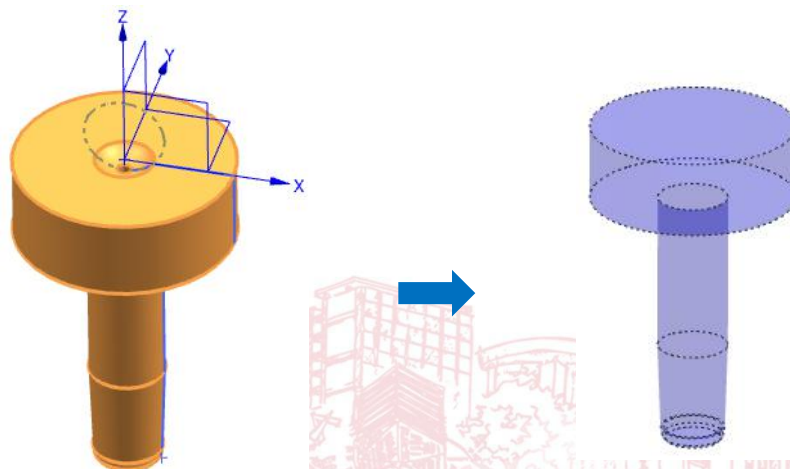
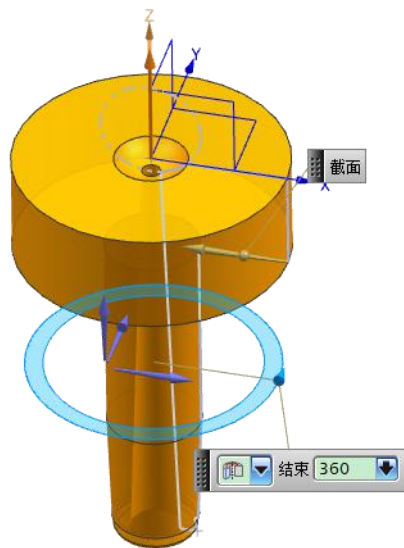



(15) 只显示回旋体，隐藏其他对象。

(16) 添加两个锁紧螺丝：M5x15，沿X方向布置，距离为25。并对浇口套求腔

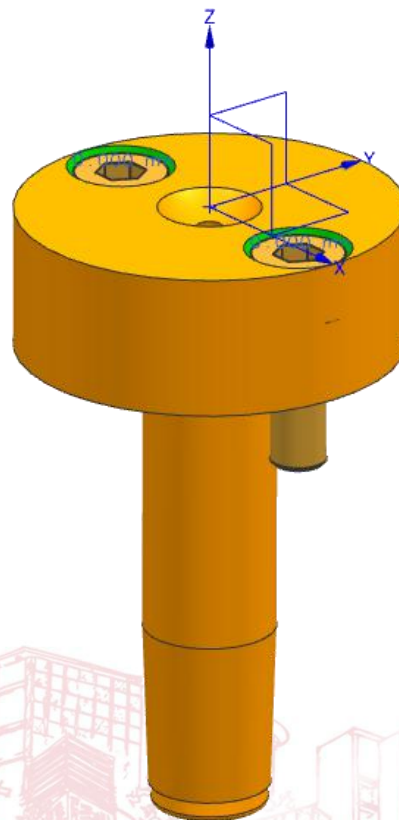



(17) 设为显示部件：17MJ001_misc_side_a_014.prt

(18) 将浇口套顶面“移动组件”到定位环底面中心

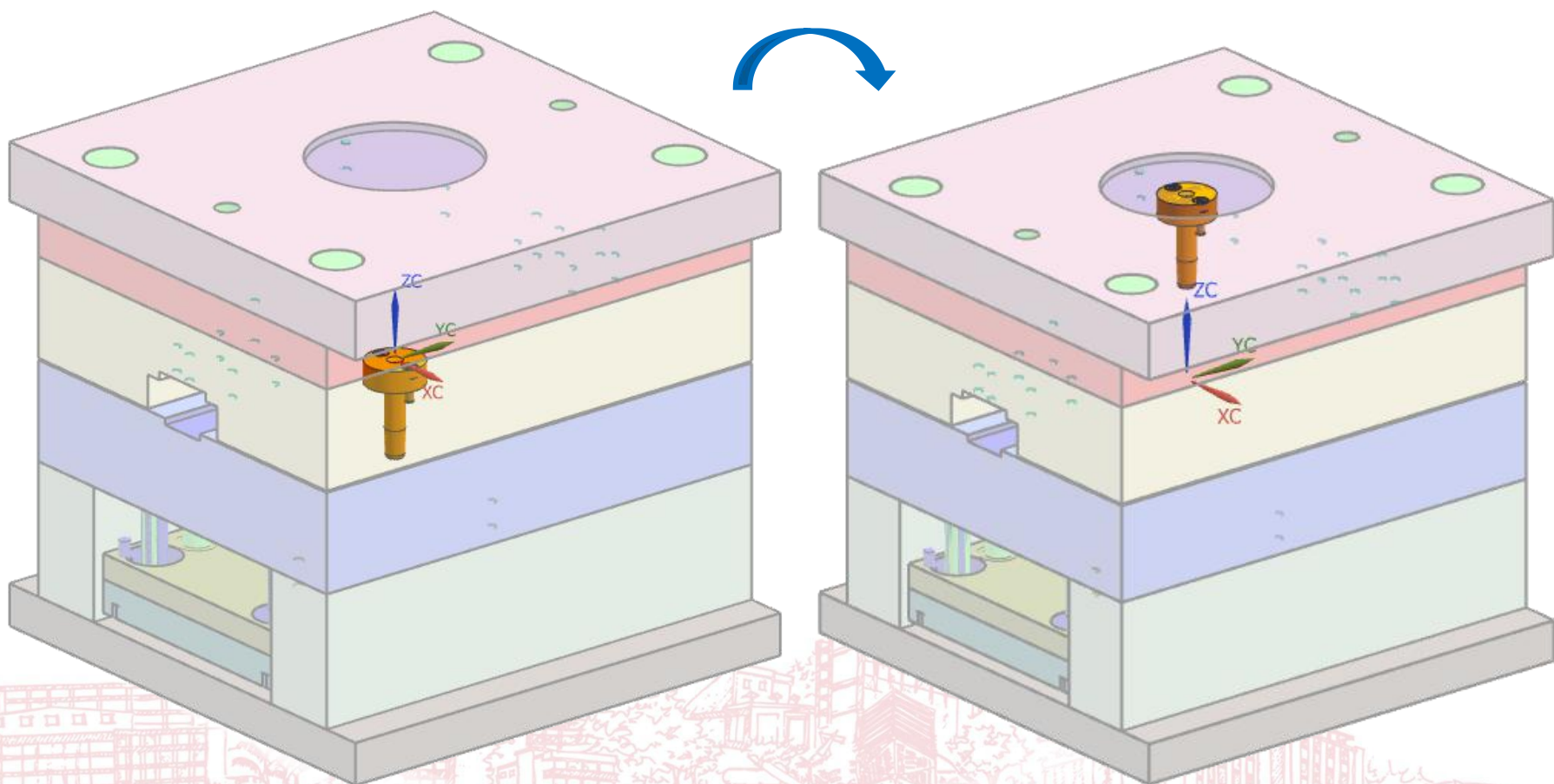



- (19) 将浇口套部件“替换引用集”为“FALSE”，对A板、水口板求腔。
- (20) 将浇口套部件“替换引用集”为“TRUE”，用两个螺丝对A板求腔。

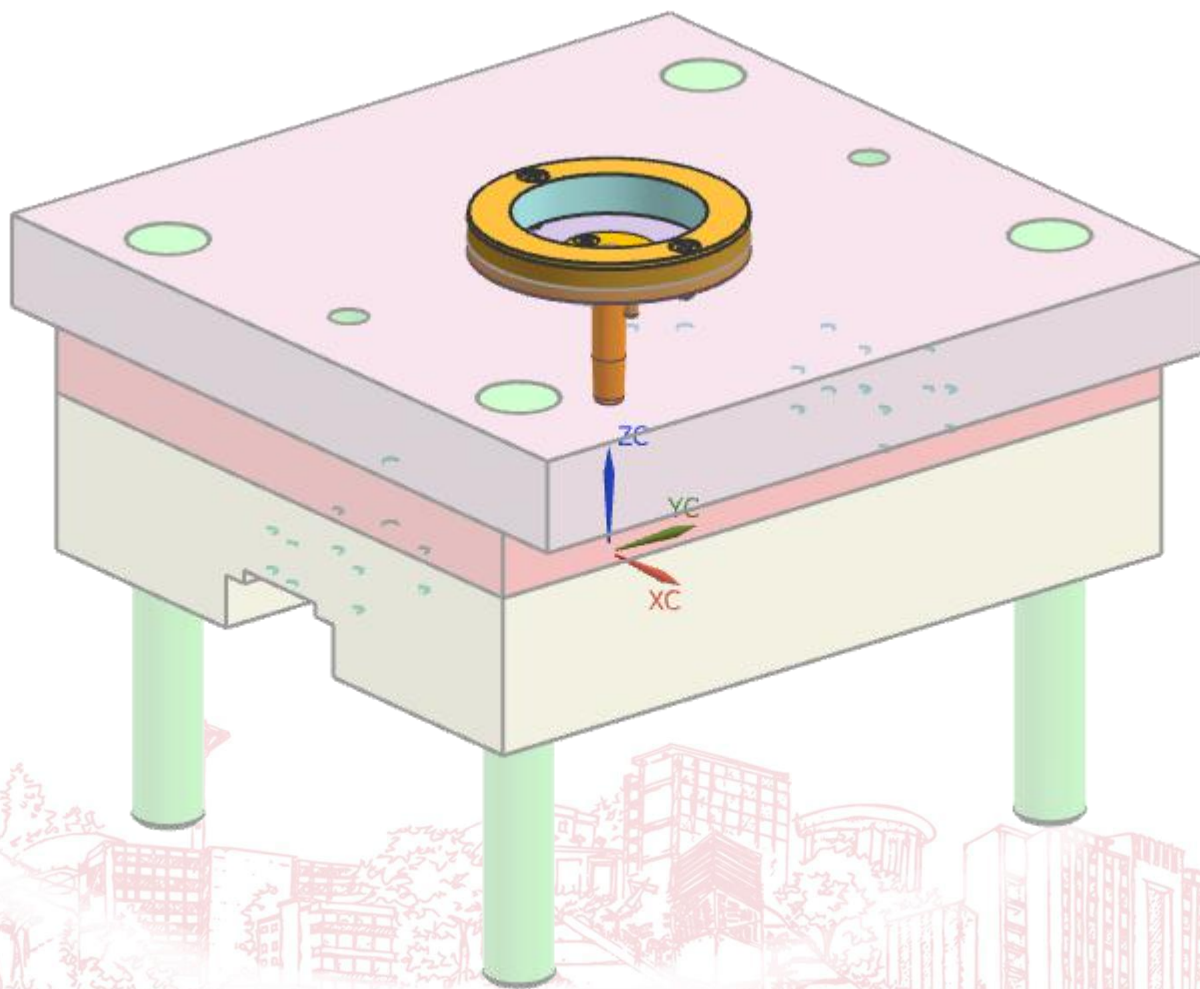



(21) 使A板成为显示部件，将与浇口套求腔得到的两个孔单边扩大0.5，做成避空

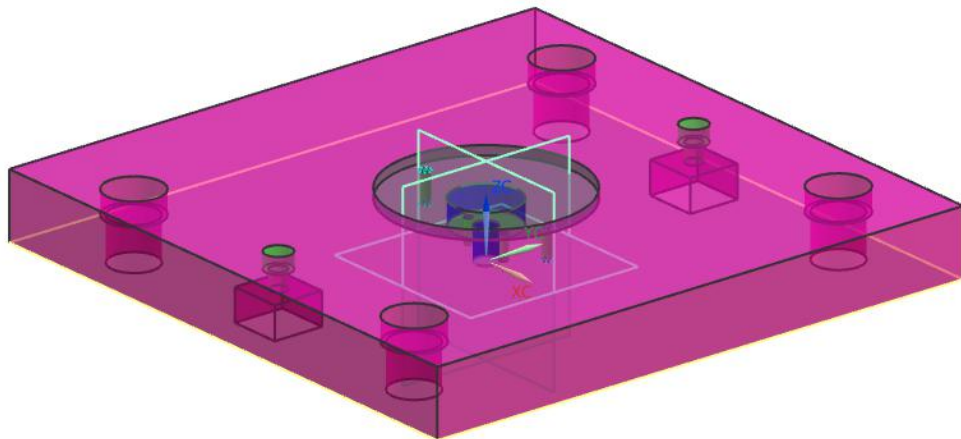



03

浇口设计



- (1) 使成为工作部件: 17MJ001_fill_011.prt
- (2) “新建组件”: 17MJ001_pin_gate.prt, 注意引用集为“仅整个部件”
- (3) 使成为显示部件: 17MJ001_pin_gate.prt
- (4) 在ZX平面上创建草图
- (5) 绘制草图曲线

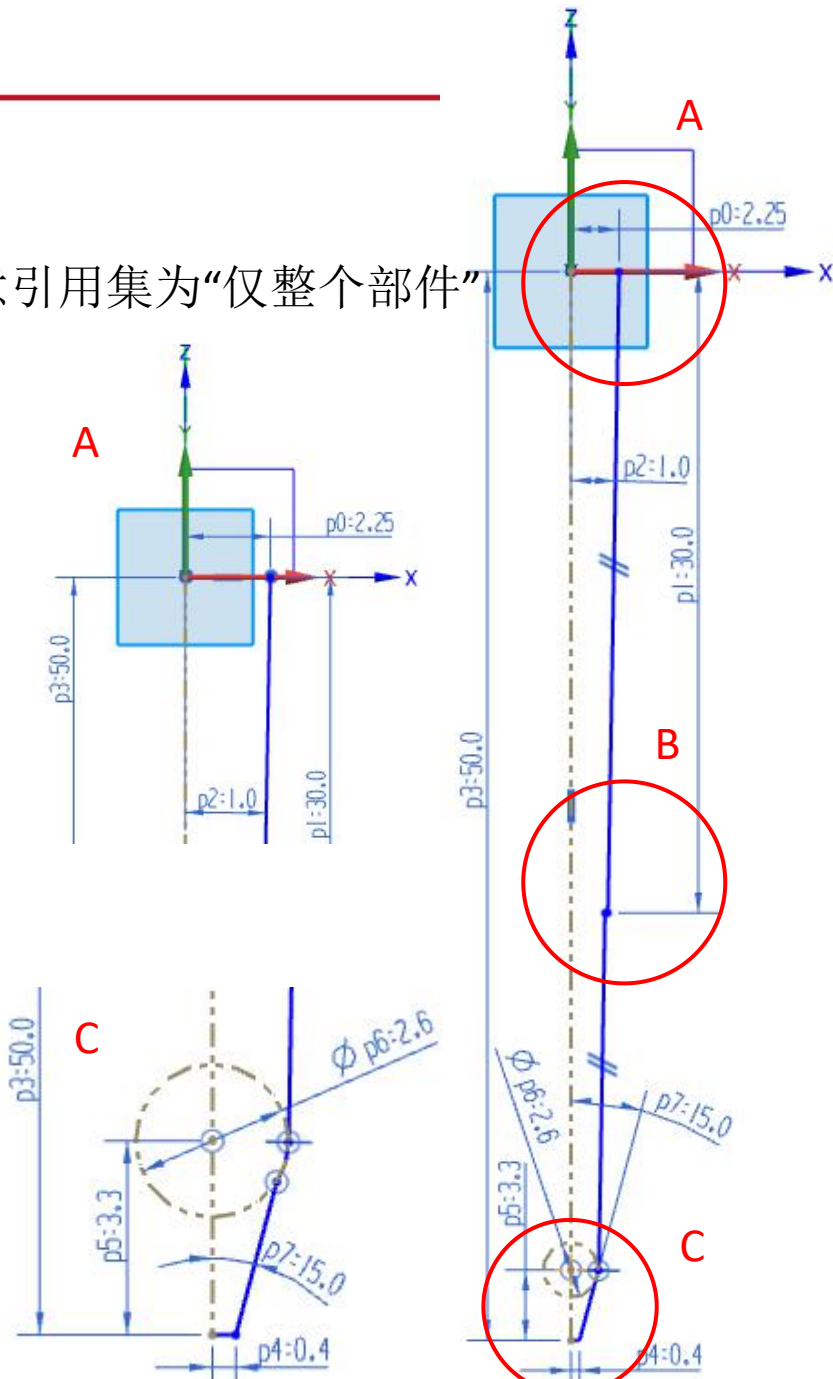
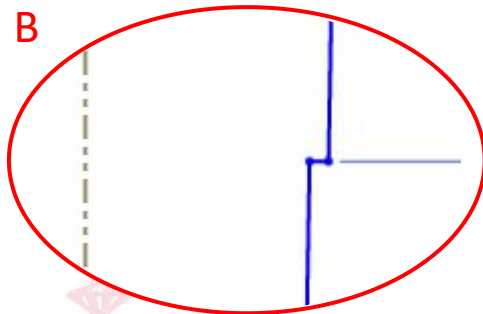



(6) 旋转草图

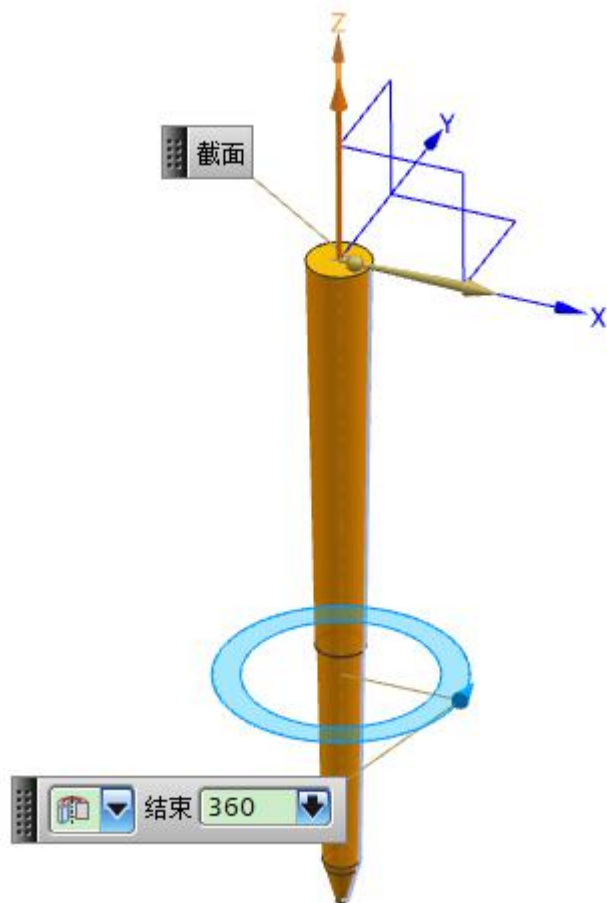

(7) 回到总装配，使成为工作部件：17MJ001_fill_011.prt

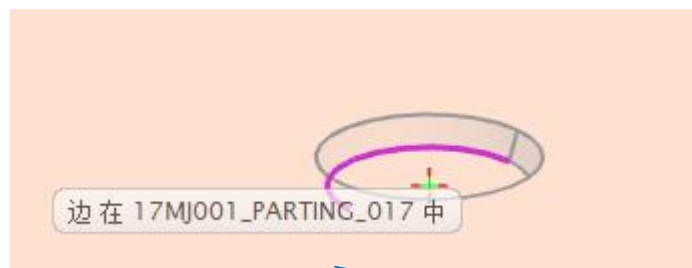

(8) 将浇口部件“移动组件”到指定边的圆心：

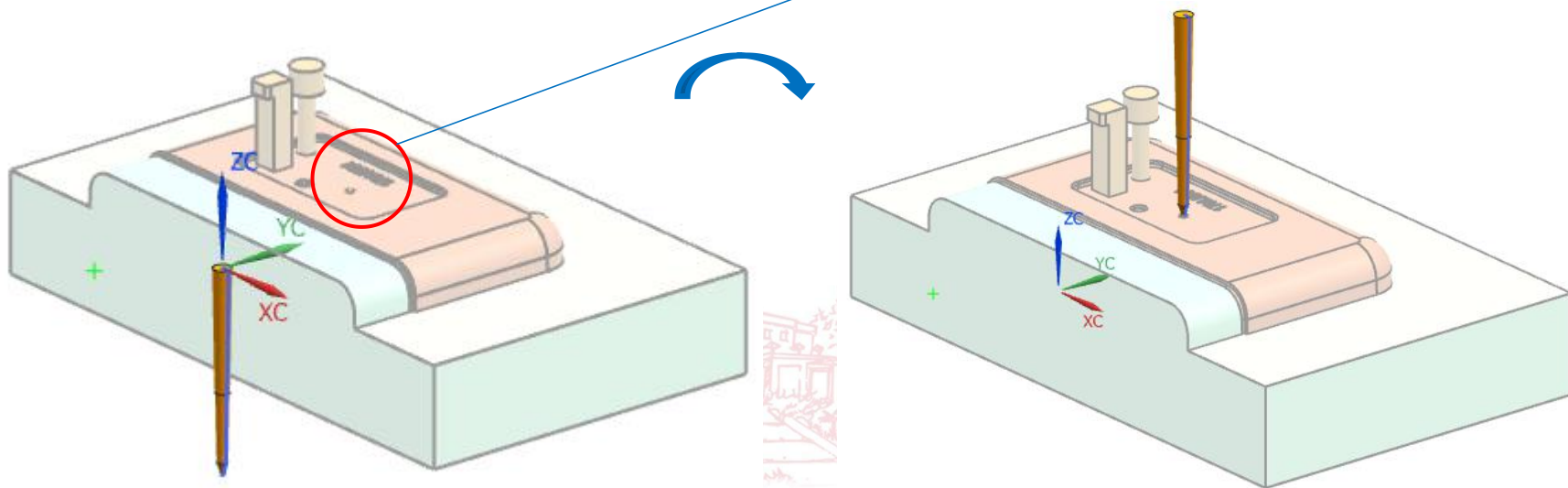



(9) 再“添加组件”到另一个型腔

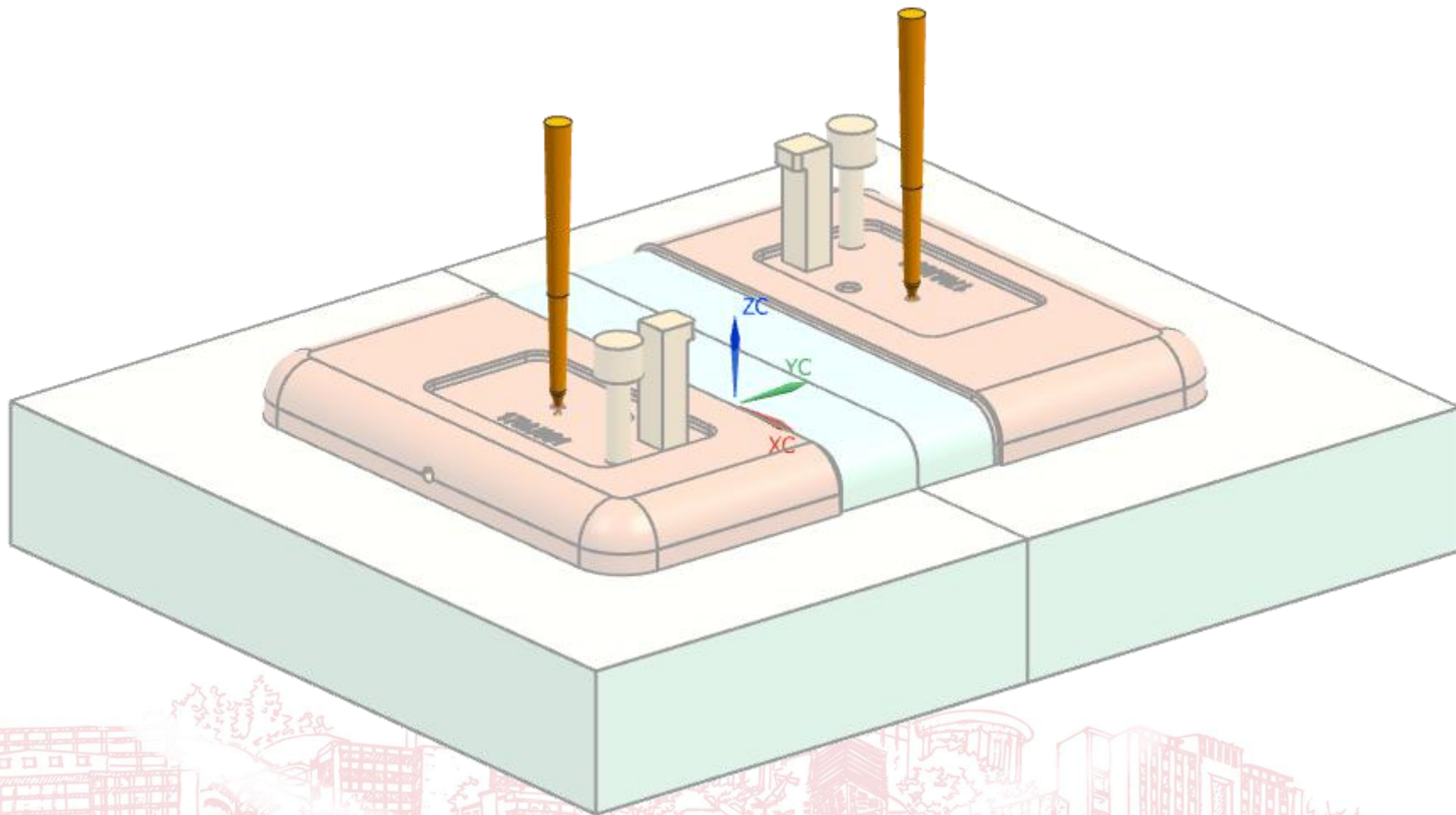



(10) 调整浇口的高度尺寸，使顶面与A板顶面平齐

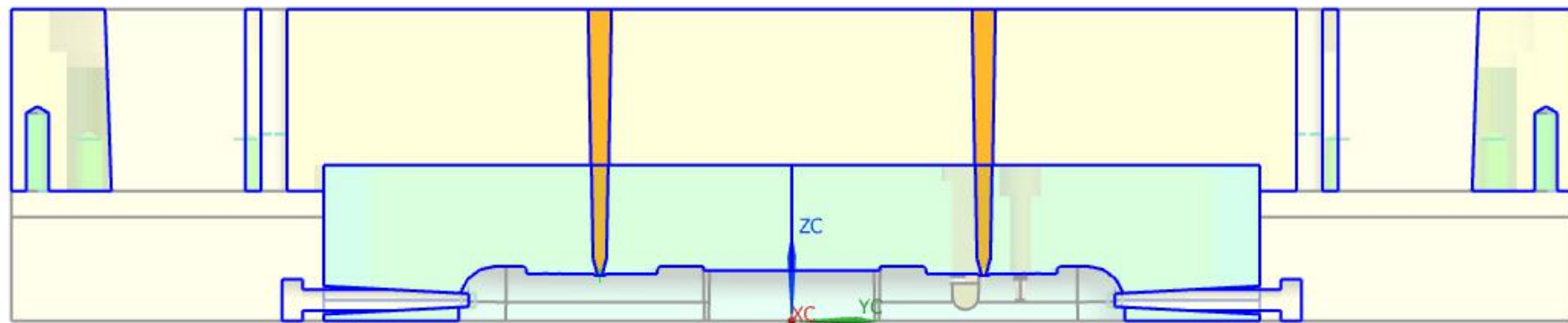
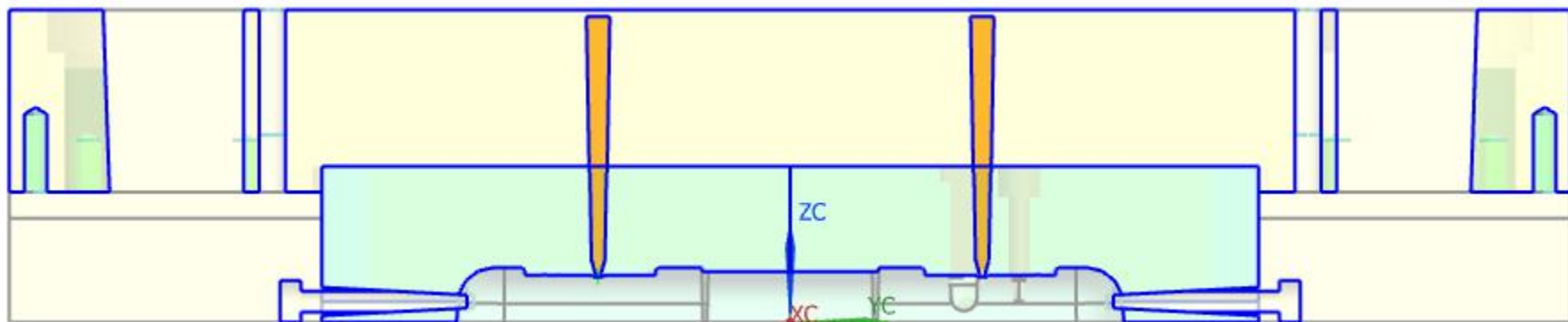



(11) 使用浇口对A板、型腔分别进行求腔

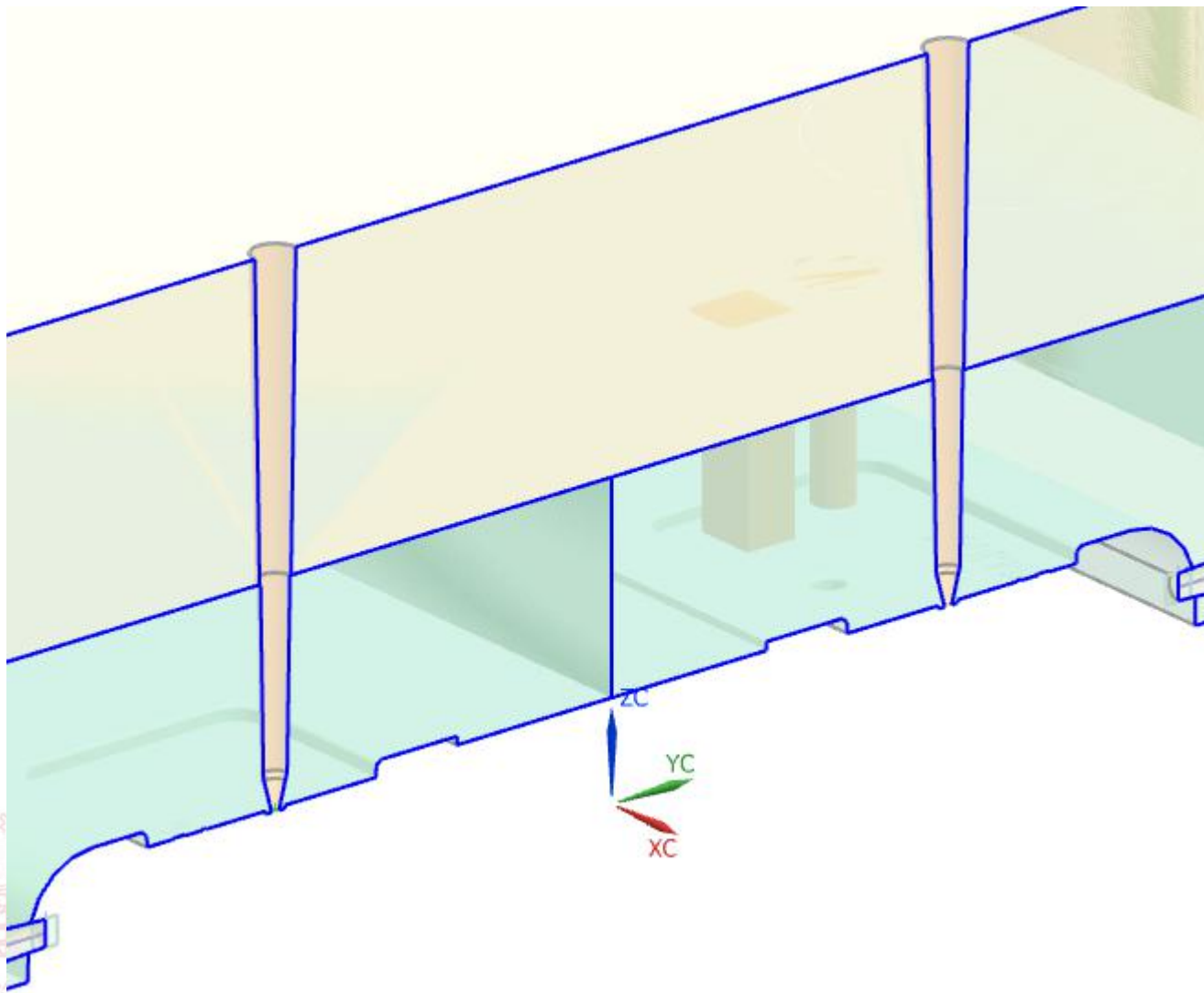



04

分流道设计





- (1) 使成为工作部件: 17MJ001_fill_011.prt
- (2) “新建组件”: 17MJ001_Channel.prt, 注意引用集为“仅整个部件”
- (3) 使成为显示部件: 17MJ001_Channel.prt
- (4) 在ZX平面上创建草图
- (5) 绘制草图曲线
- (6) 拉伸草图曲线: 对称, 44mm

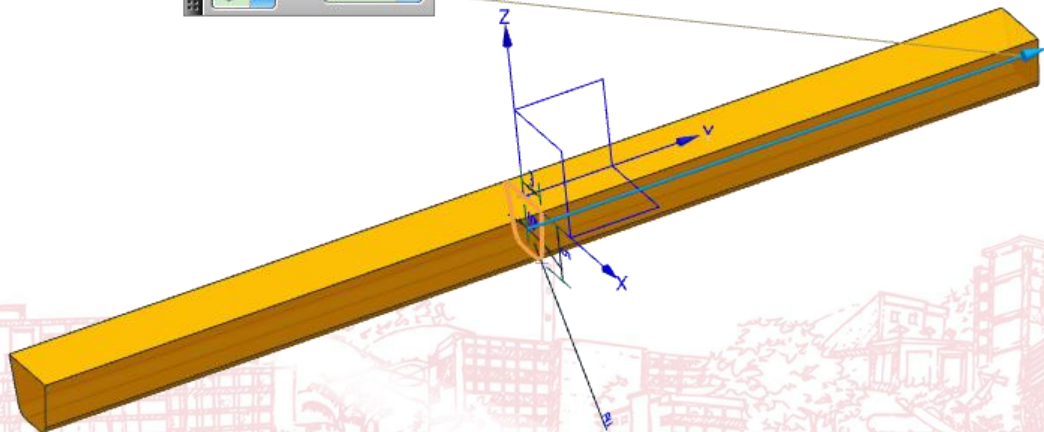
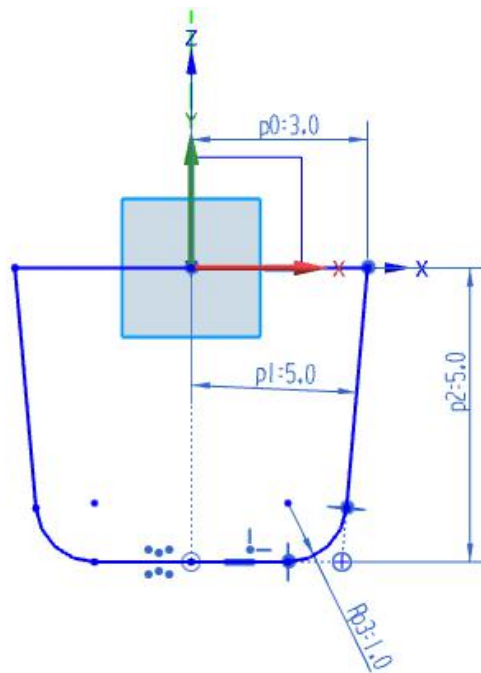



(7) 在底面中心上创建草图，绘制一个 $\Phi 16$ 的圆

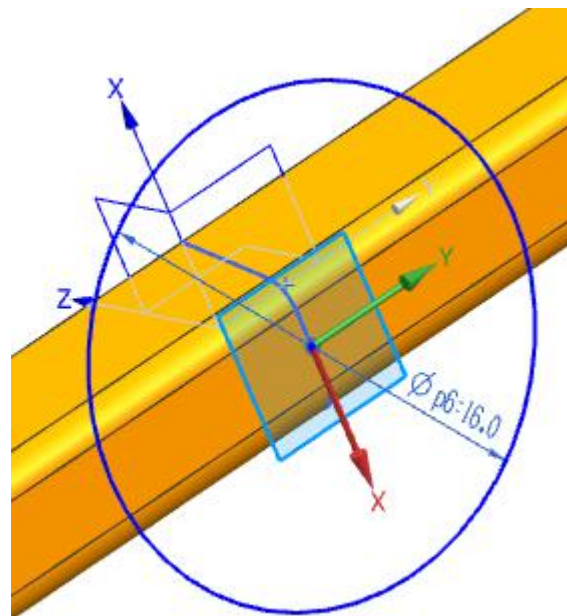
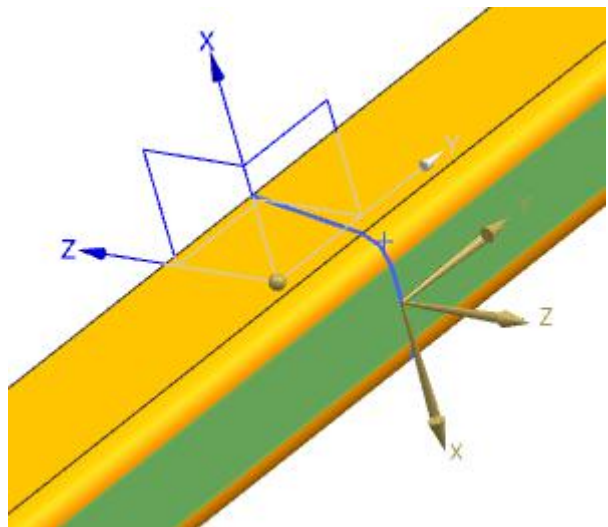



(8) 拉伸：拔模角度10°

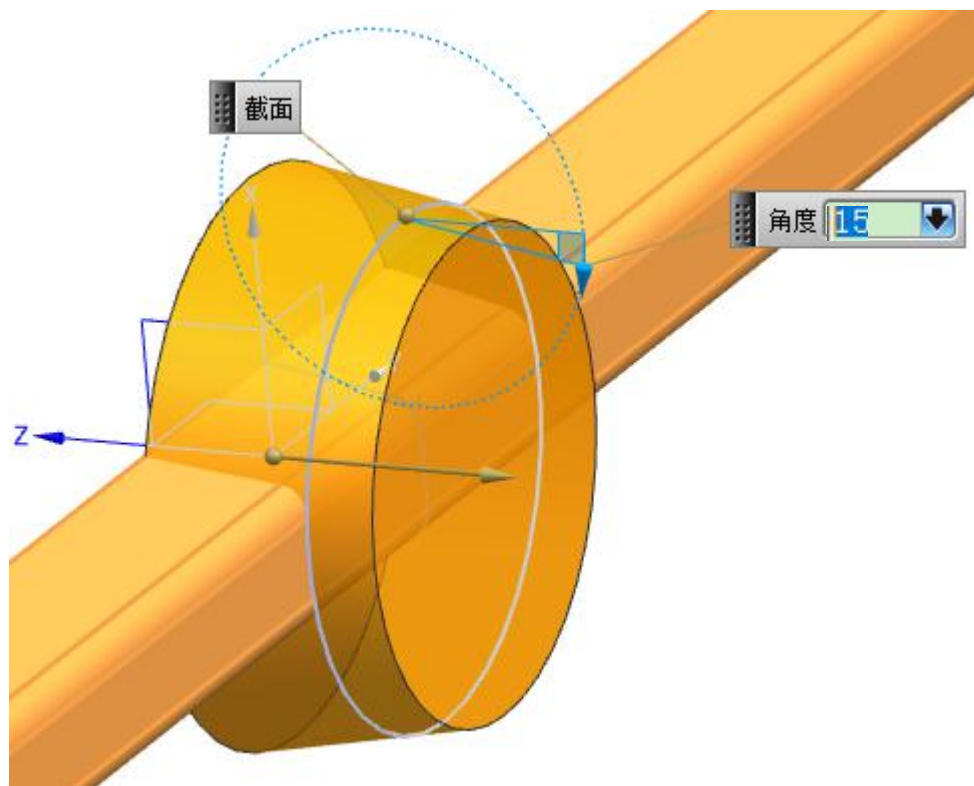



(9) 倒圆角1mm

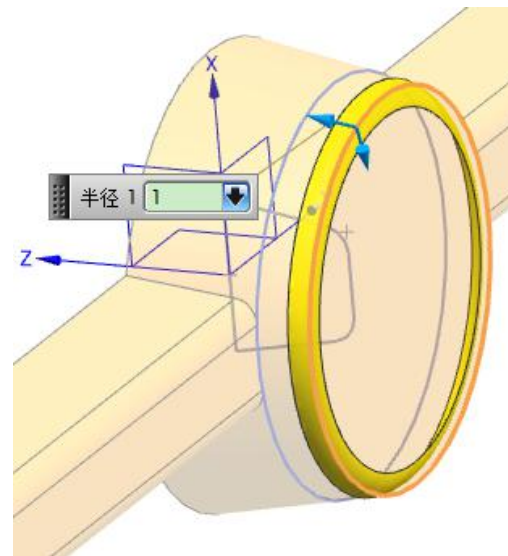

(10) 两个端面拔模: 5°

(11) 两端倒圆角1mm

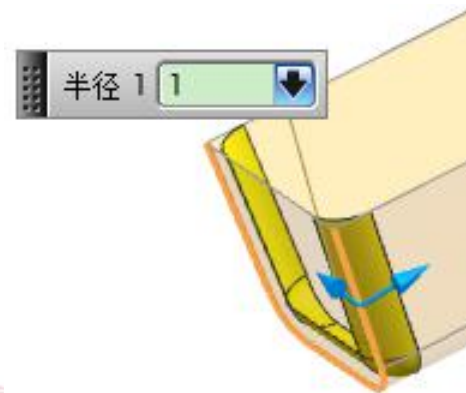
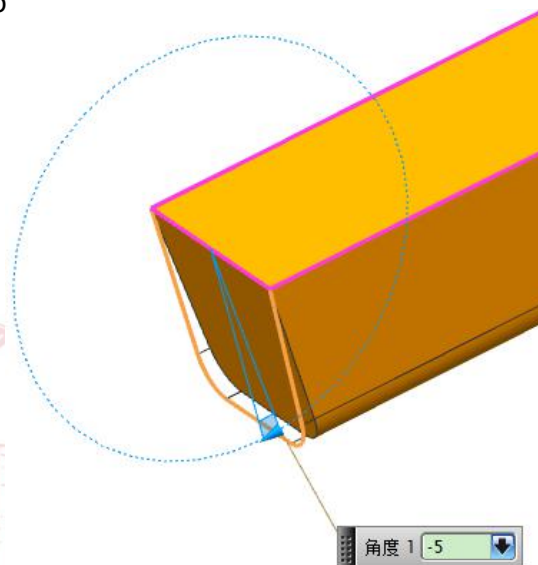



(12) 使成为工作部件: 17MJ001_fill_011.prt, 移动分流道部件

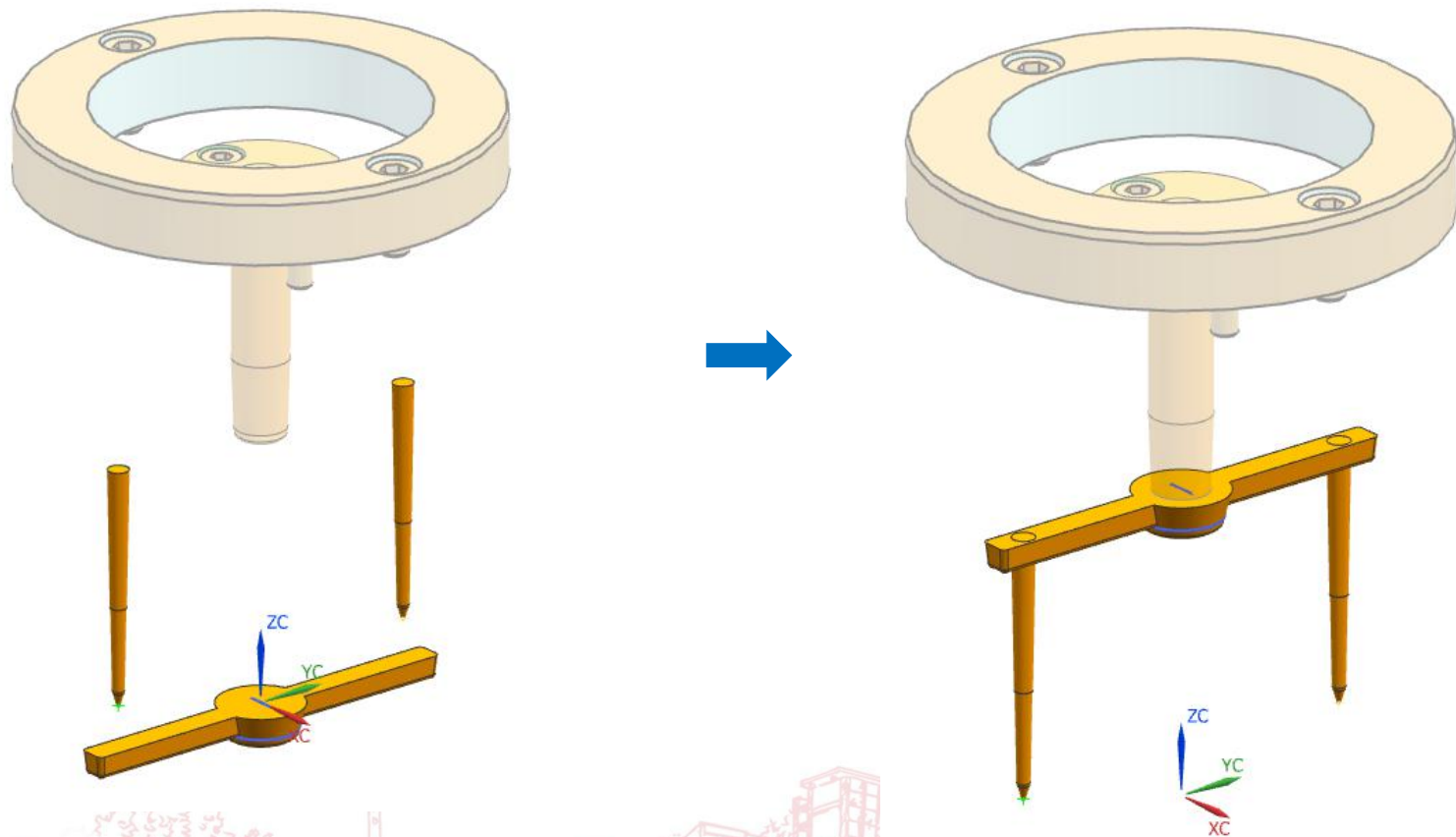



(13) 用分流道实体，对A板求腔

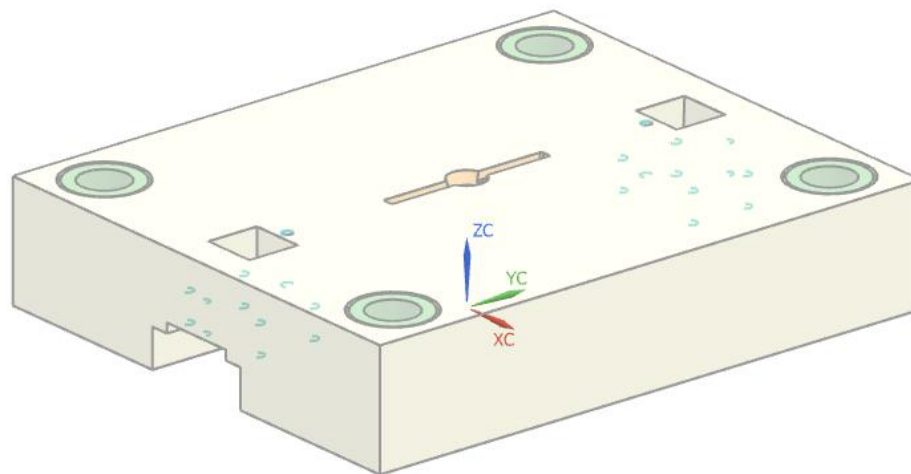
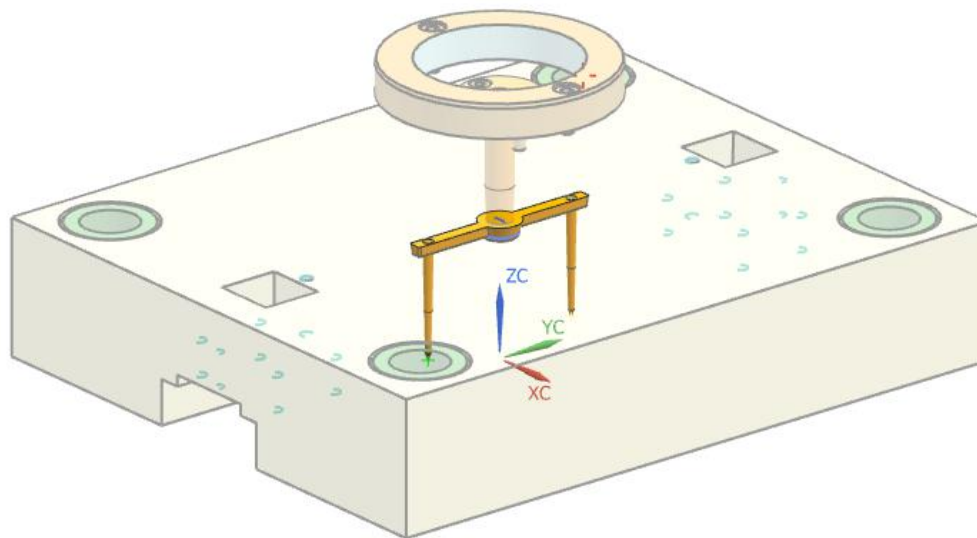



(14) 回到总装配，使成为工作部件，保存。

(15) 仅显示浇注系统，观察结构。

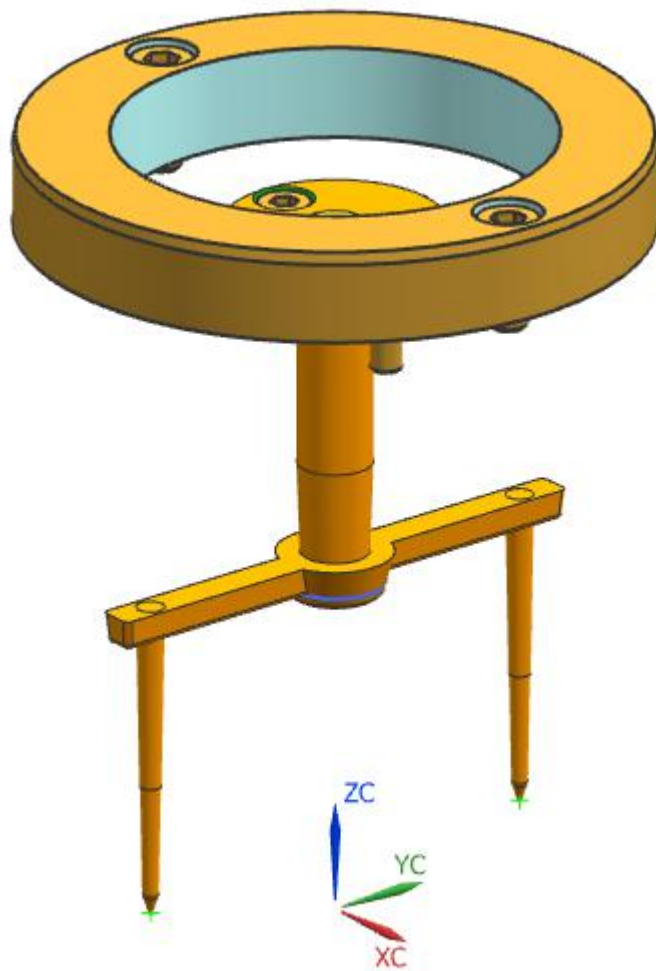



05

拉料杆设计





(1) 添加拉料杆

标准件管理

文件夹视图

- 名称
 - FUTABA_MM
 - Sprue Puller
 - Guides

成员视图

对象	标准
Sprue Puller [M-RLA]	Mold

父: 17MJ001_misc_side_a_014

位置: REPOSITION

引用集: TRUE

详细信息

名称	值
CATALOG_DIA	5
CATALOG_LEN...	33
HEAD_DIA	9
HEAD_HEIGHT	6
PULLER_OD	4
PULLER_ID	3
PULLER_HEIGHT	3
CLEARANCE_DIA	5
C_BORE_DIA	9.5
C_BORE_DEEP	6
CLEARANCE_LE...	CATALO

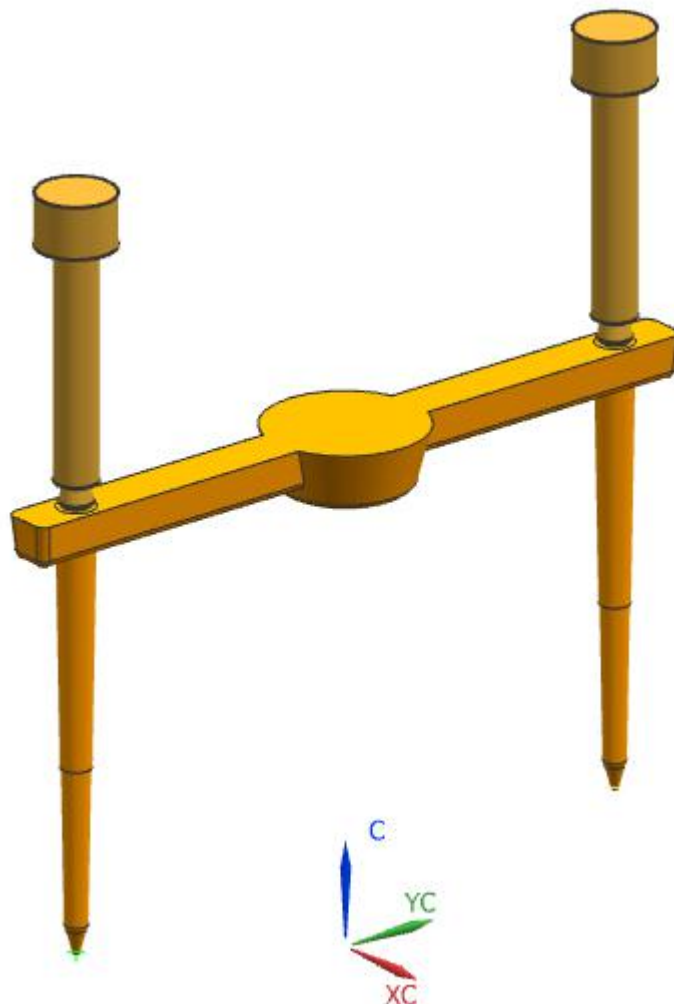

(2) 添加无头螺丝

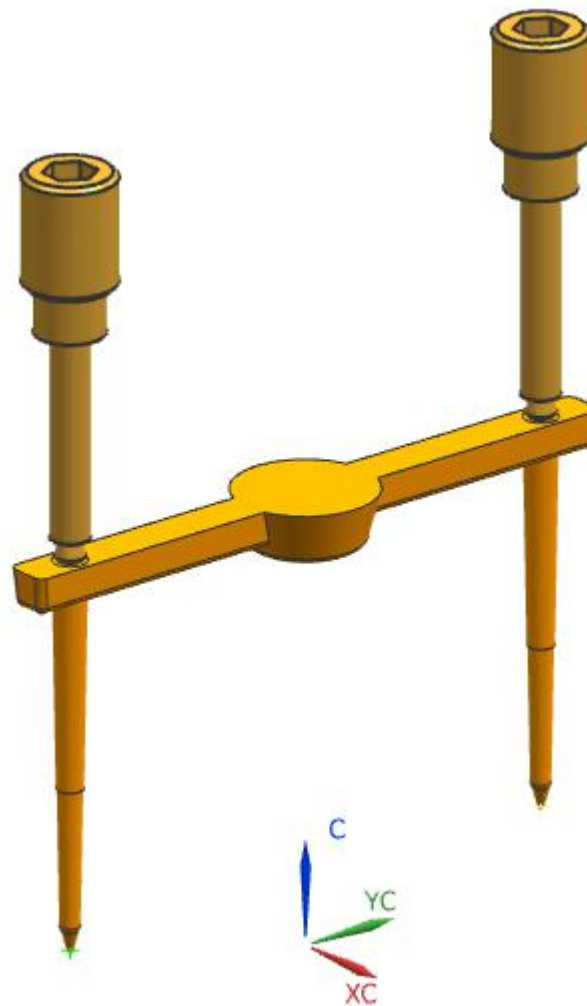



(3) 拉料杆、无头螺丝对A板、水口板求腔

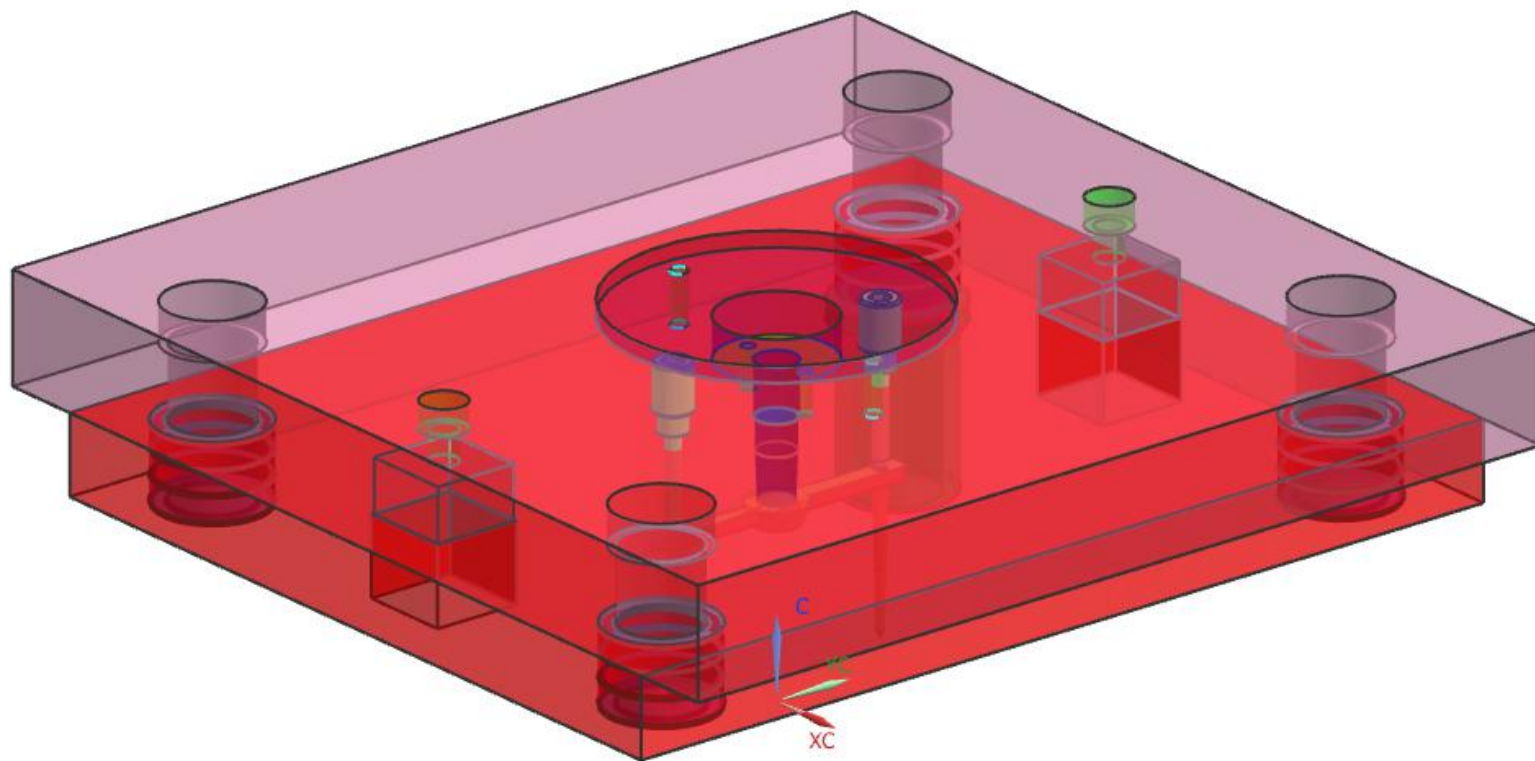



06

2D绘图





(1) 显示浇注系统的相关部件

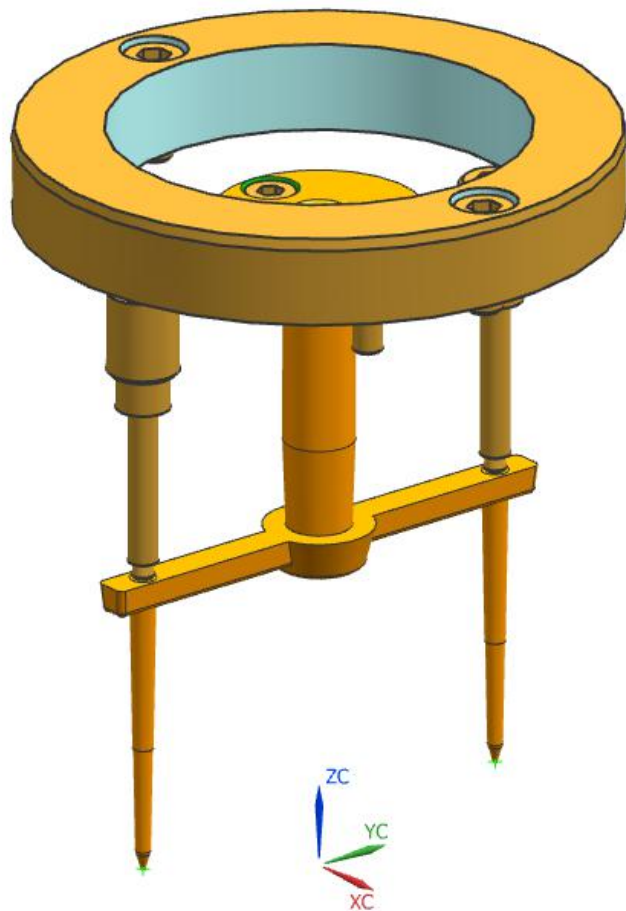



(2) 创建浇注系统投影，隐藏剖面线

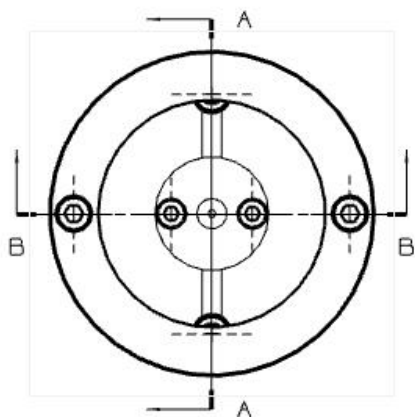

SECTION A-A

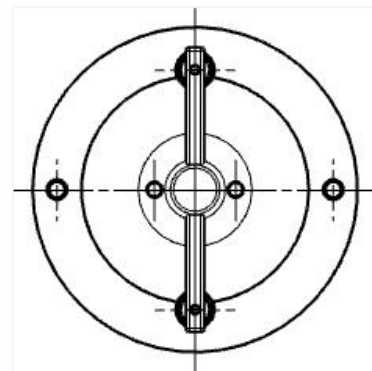
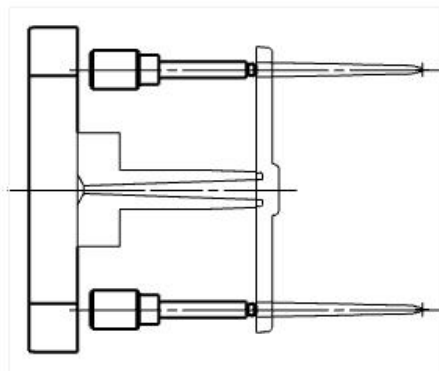

SECTION B-B

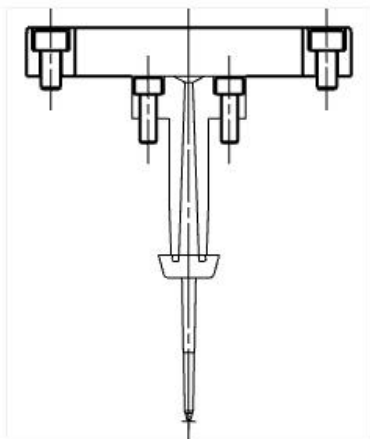

(3) 导出投影并复制到2D总装配图

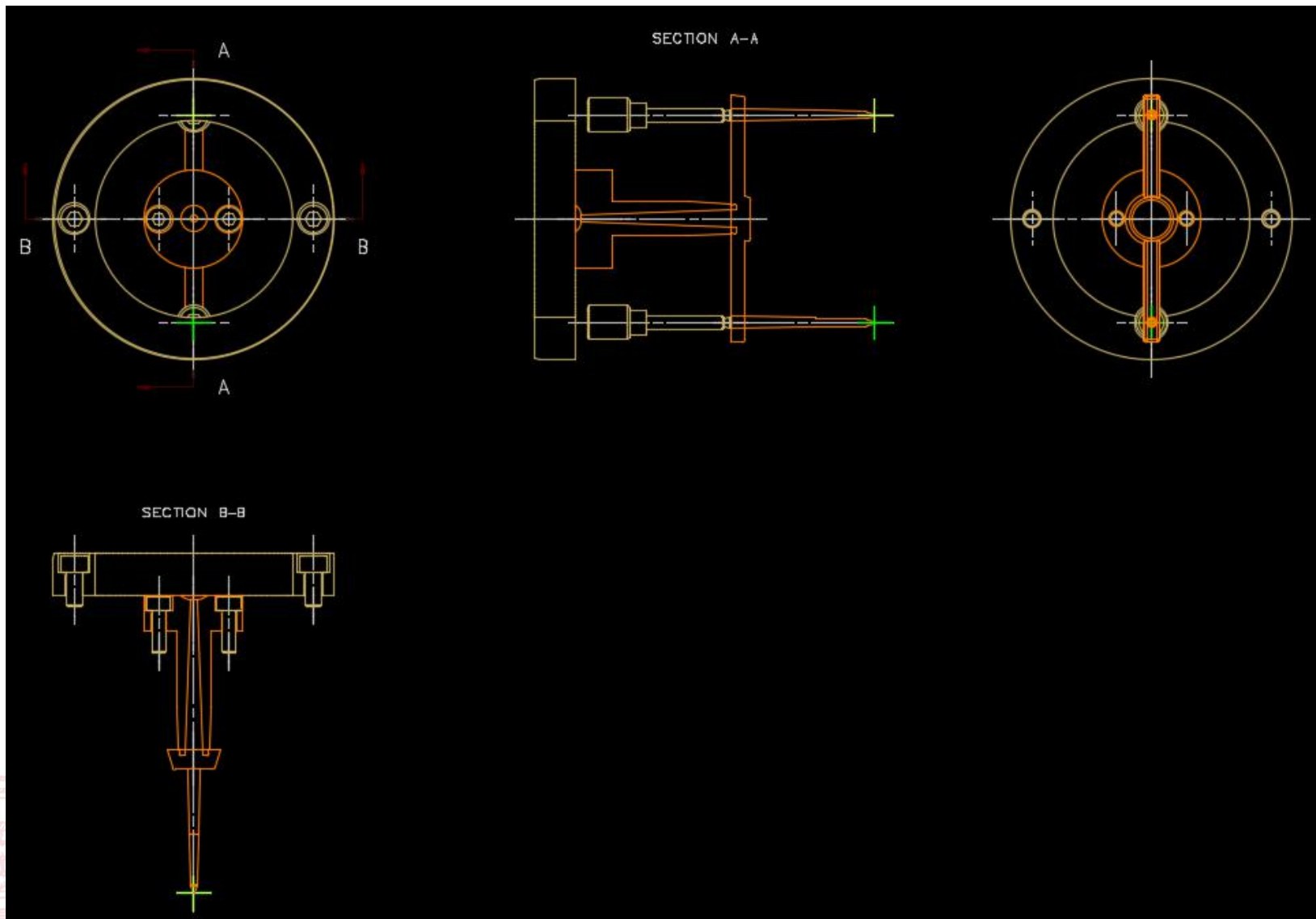



(4) 将B-B剖视图整理后，复制到主视图

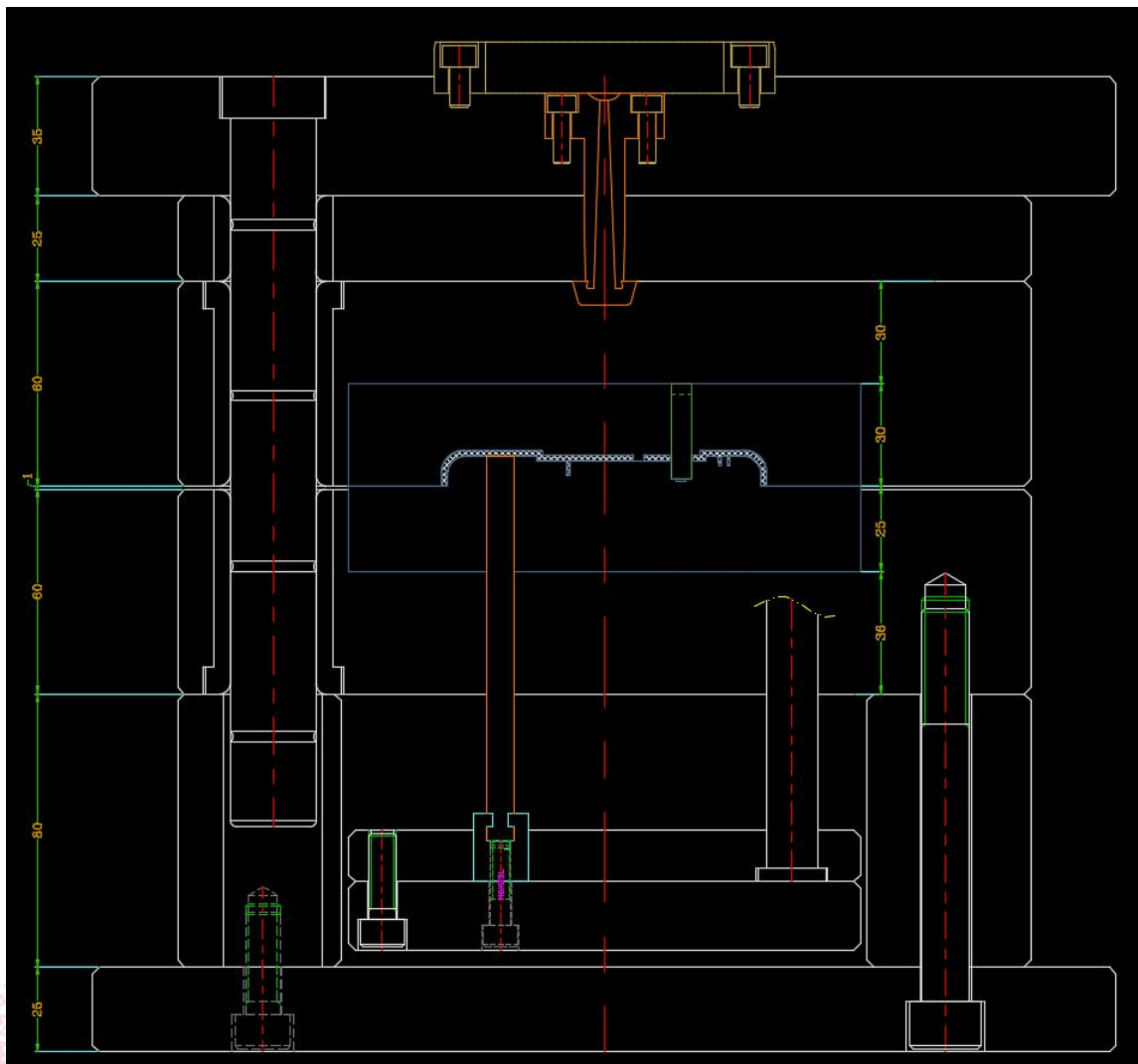
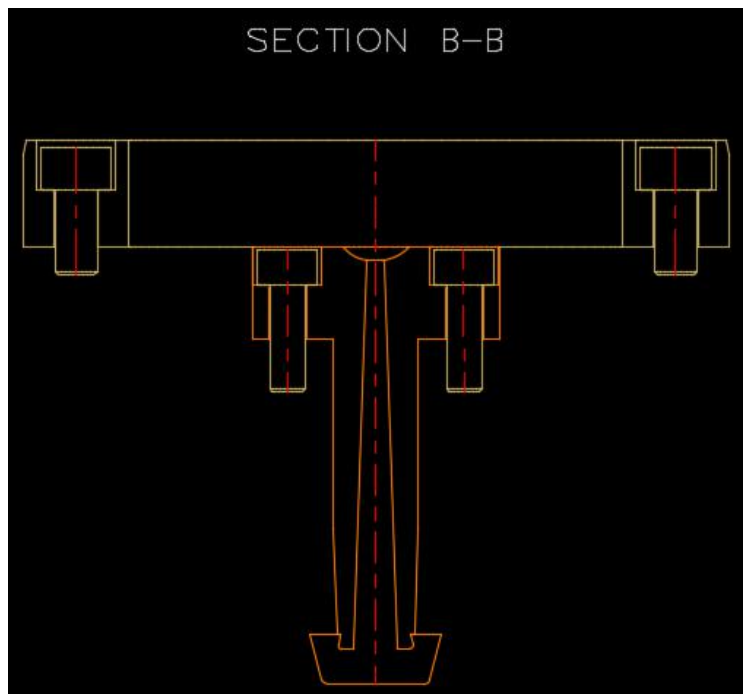



(5) 将A-A剖视图整理后，复制到侧视图

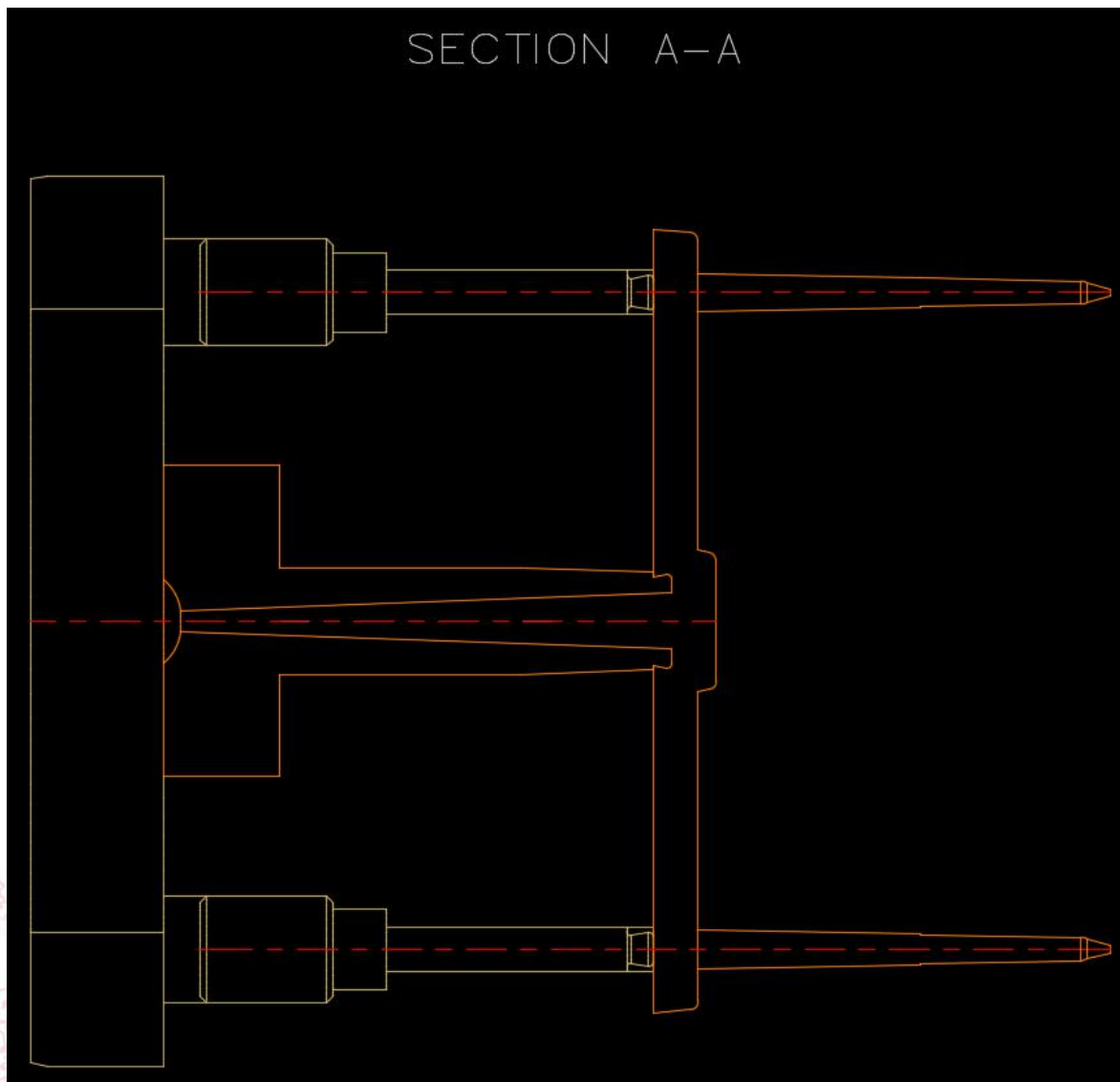

接下页.....

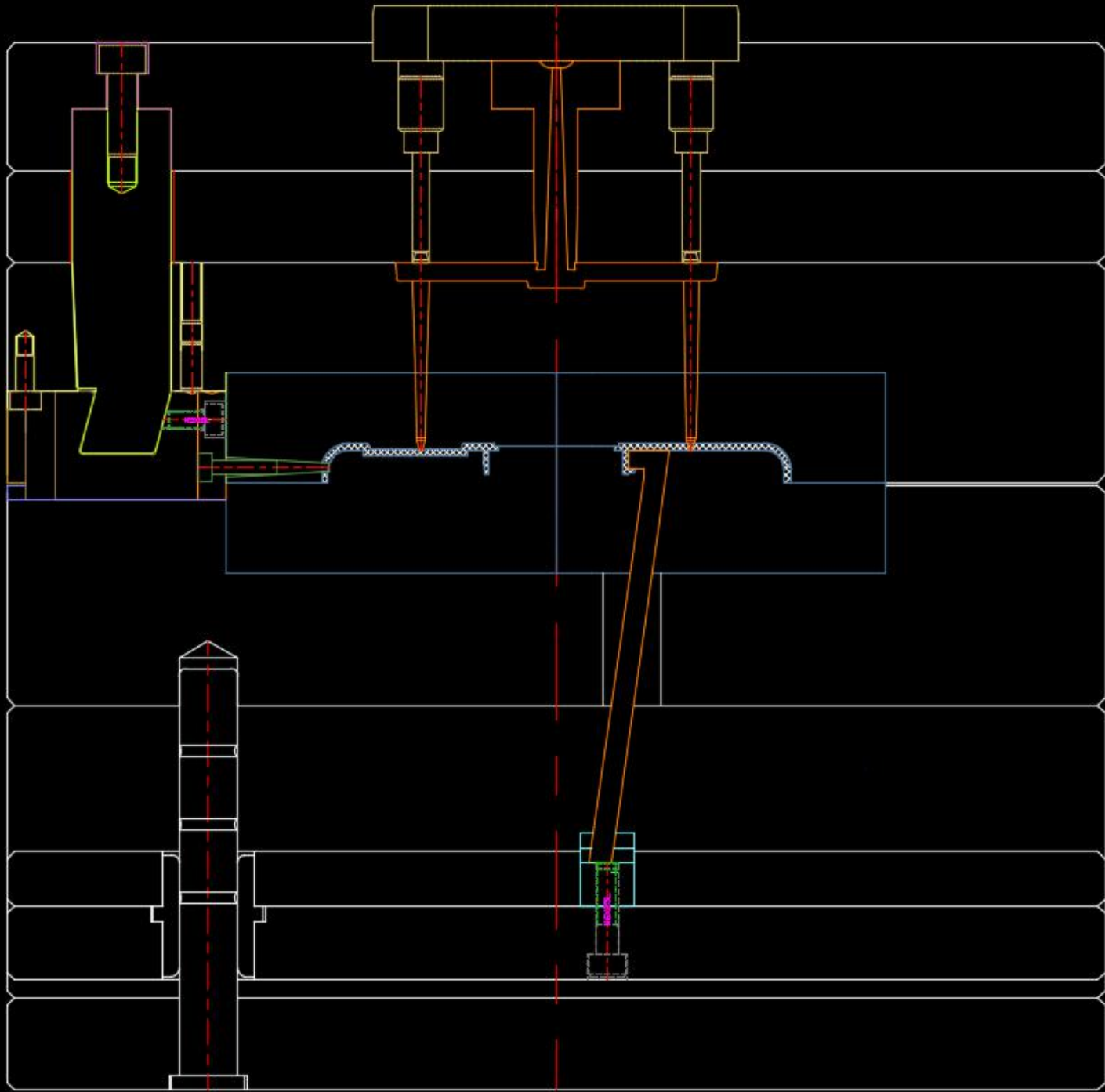



(6) 将仰视图整理，复制到上模视图

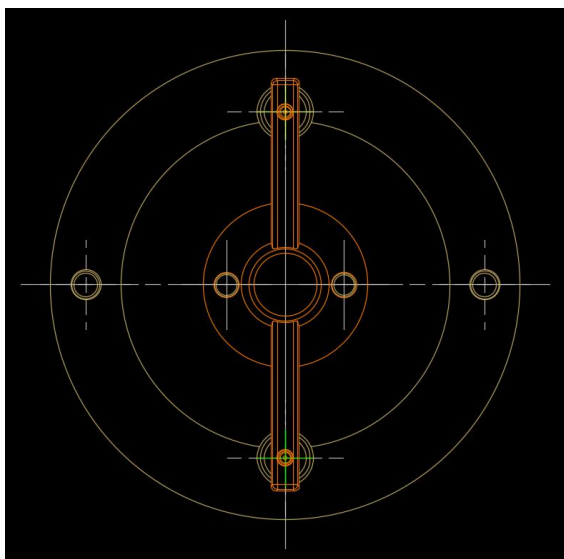

接下页.....

